

A company dedicated to solving ergonomic and material handling problems since 1955.

Loading Dock Equipment

OWNER'S MANUAL

DOCK SEALS

MODELS D-150 & D-350

Contents

Materials List	1	Parts Drawing	2
Receiving Instructions	1	Parts List.....	2
Installation Instructions	1		

MATERIALS INCLUDED IN BASE KIT

- 1 Dock Seal Top
- 2 Dock Seal Sides
- 5 Angle Brackets
- 6 Flat Brackets
- 7 Wall Bolts with Nuts
- 22 Wood Lag Screws
- 14 3/8" Nuts
- 14 Flat Washers

* All buildings and installations are unique. Actual hardware needed may vary.

RECEIVING INSTRUCTIONS

Every unit is thoroughly tested and inspected prior to shipment. However, it is possible that the unit may incur damage during transit. If damage is noticed when unloading, make a note of it on the BILL OF LADING. Remove all packing and strapping material, then inspect the unit again for damage. IF DAMAGE IS EVIDENT, FILE A CLAIM WITH THE CARRIER IMMEDIATELY!

INSTALLATION

1. Mount side pieces with vents at bottom.
2. The top piece is identifiable because it does not have vents on either end.
3. Measure the length of the top foam to determine the outside width dimension.
4. Installation of the sides first is recommended. It is easier to install all brackets on sides prior to erection.
5. Install top with at least one (1) bolt at each end and one (1) in the center.
6. For best seal, caulk around perimeter.

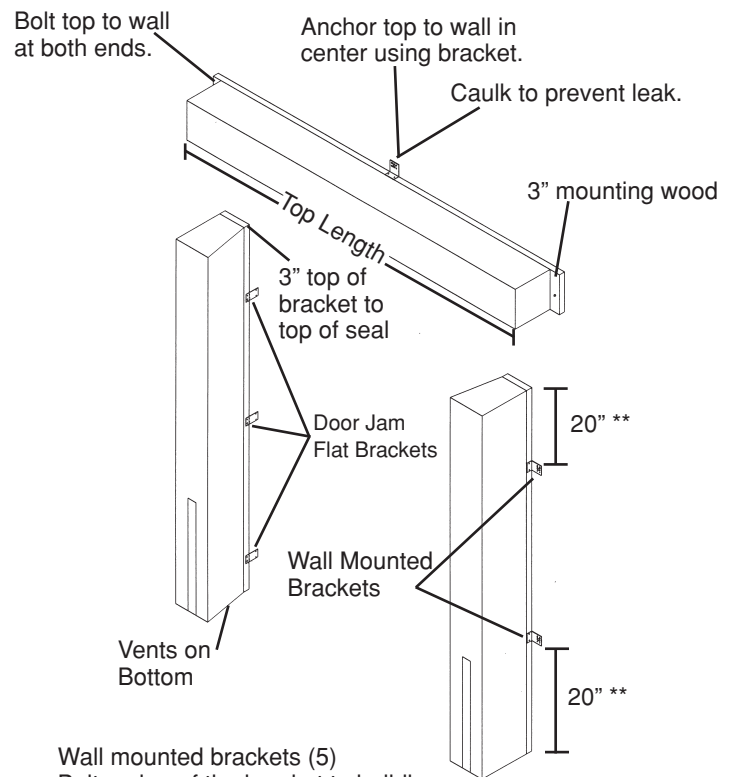

Wall mounted brackets (5)
Bolt on leg of the bracket to building
Bolt other leg to side of dock seal using the two lag bolts provided.

Door jamb brackets (6)
Fasten one side to bracket to door jamb and lag bolt the other side to the mounting board using the two lag bolts provided, See Section A-A

*D-150 shown.
Distance may vary depending on building structure.
** Dimensions are approximate recommendations.*

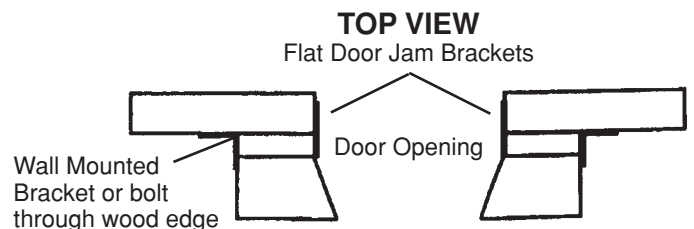

PARTS DRAWING DOCK SEALS

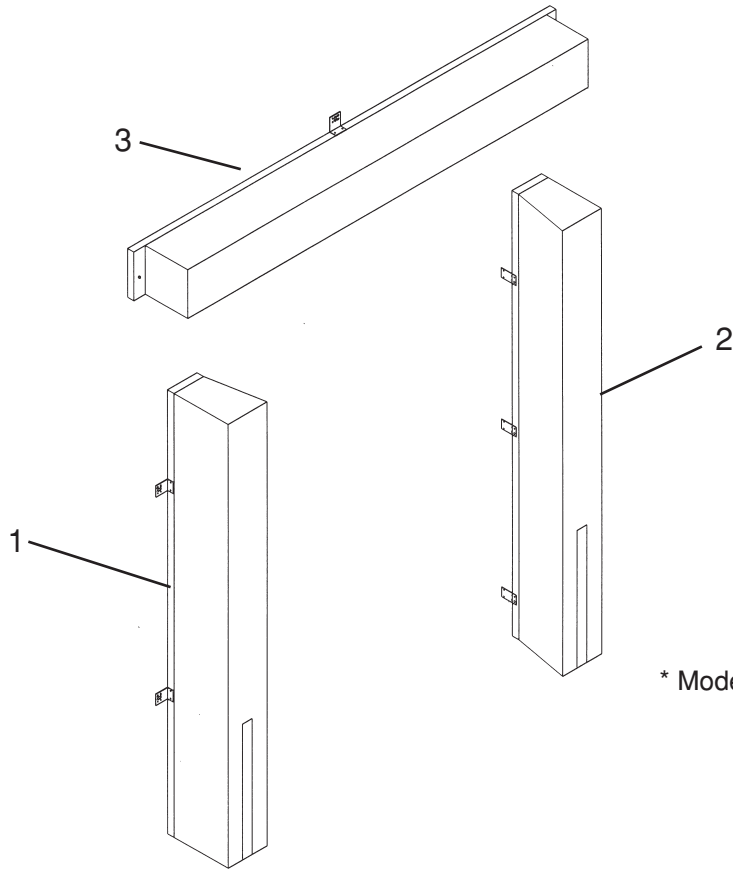

* Model D-150 shown

Item No.	Description	Part No.	Qty.
1a	D-150 Right Side Replacement (10" projection)	D150-10-RS	1
1b	D-150 Right Side Replacement (20" projection)	D150-20-RS	1
1c	D-350 Right Side Replacement (10" projection)	D350-10-RS	1
1d	D-350 Right Side Replacement (20" projection)	D350-20-RS	1
2a	D-150 Left Side Replacement (10" projection)	D150-10-LS	1
2b	D-150 Left Side Replacement (20" projection)	D150-20-LS	1
2c	D-350 Left Side Replacement (10" projection)	D350-10-LS	1
2d	D-350 Left Side Replacement (20" projection)	D350-20-LS	1
3a	D-150 Top Replacement (10" projection)	D150-10-TOP	1
3b	D-150 Top Replacement (20" projection)	D150-20-TOP	1
3c	D-350 Top Replacement (10" projection) with 12" flap	D350-10-TOP	1
3d	D-350 Top Replacement (20" projection) with 12" flap	D350-20-TOP	1
4	Installation Hardware Kit (not shown) (includes 5 angle brackets, 6 flat brackets, 5 wall bolt nuts, 22 wood lag screws)	D150/350-HDWR	1

* Contact factory for information on custom sizes.

* Product safety signs or labels should be periodically inspected and cleaned by the product users as necessary to maintain good legibility for safe viewing distance. ANSI 535.4 (10.21) Contact manufacturer for replacement labels.

LIMITED WARRANTY

Vestil Manufacturing Corporation (“Vestil”) warrants this product to be free of defects in material and workmanship during the warranty period. *Our warranty obligation is to provide a replacement for a defective original part if the part is covered by the warranty, after we receive a proper request from the warrantee (you) for warranty service.*

Who may request service?

Only a warrantee may request service. *You are a warrantee if you purchased the product from Vestil or from an authorized distributor AND Vestil has been fully paid.*

What is an “original part”?

An original part is a part used to make the product as shipped to the warrantee.

What is a “proper request”?

A request for warranty service is proper if Vestil receives: 1) a photocopy of the Customer Invoice that displays the shipping date; AND 2) a written request for warranty service including your name and phone number. Send requests by any of the following methods:

Mail
Vestil Manufacturing Corporation
2999 North Wayne Street, PO Box 507
Angola, IN 46703

Fax
(260) 665-1339
Phone
(260) 665-7586

Email
sales@vestil.com

In the written request, list the parts believed to be defective and include the address where replacements should be delivered.

What is covered under the warranty?

After Vestil receives your request for warranty service, an authorized representative will contact you to determine whether your claim is covered by the warranty. Before providing warranty service, Vestil may require you to send the entire product, or just the defective part or parts, to its facility in Angola, IN. The warranty covers defects in the following *original* dynamic components: motors, hydraulic pumps, electronic controllers, switches and cylinders. It also covers defects in *original* parts that wear under normal usage conditions (“wearing parts”): bearings, hoses, wheels, seals, brushes, batteries, and the battery charger.

How long is the warranty period?

The warranty period for original components is 90 days. The warranty period begins on the date when Vestil ships the product to the warrantee. If the product was purchased from an authorized distributor, the period begins when the distributor ships the product. Vestil may extend the warranty period for products shipped from authorized distributors by *up to 30 days* to account for shipping time.

If a defective part is covered by the warranty, what will Vestil do to correct the problem?

Vestil will provide an appropriate replacement for any *covered* part. An authorized representative of Vestil will contact you to discuss your claim.

What is not covered by the warranty?

1. Labor;
2. Freight;
3. Occurrence of any of the following, which automatically voids the warranty:
 - Product misuse;
 - Negligent operation or repair;
 - Corrosion or use in corrosive environments;
 - Inadequate or improper maintenance;
 - Damage sustained during shipping;
 - Collisions or other incidental contacts causing damage to the product;
 - Unauthorized modifications: DO NOT modify the product IN ANY WAY without first receiving written authorization from Vestil. Modification(s) might make the product unsafe to use or might cause excessive and/or abnormal wear.

Do any other warranties apply to the product?

Vestil Manufacturing Corp. makes no other express warranties. All implied warranties are disclaimed to the extent allowed by law. Any implied warranty not disclaimed is limited in scope to the terms of this Limited Warranty.

